

The Ray Allen Company Inc.

1341 Distribution Way Ste 15, Vista, CA 92081 USA Ph 760 599 4720 Fx 760 599 4383
www.rayallencompany.com

REG-1 VOLTAGE REGULATOR (28V-12V)

INSTALLATION INSTRUCTIONS

Install the REG-1 voltage regulator at any convenient location preferably near the trim switch or indicator.

The internal regulator has a 1 amp capacity. However, because of the small heat sink, we do not recommend a constant load of more than 200mA. You can operate a maximum of 2 separate trim systems off of one REG-1 voltage regulator.

The REG-1 voltage regulator gets HOT when loaded past 200mA. Be sure wherever you mount it has enough cooling air circulation.

Secure to the airframe with screws through its mounting flange or simply tie onto a wire bundle with nylon straps, etc. It is not necessary to ground the case of this unit.

Wire according to the wiring diagram below. Use appropriate wire connectors or solder all connections and use a heat-shrinkable tubing for insulation. Fuses and circuit breakers are not included.

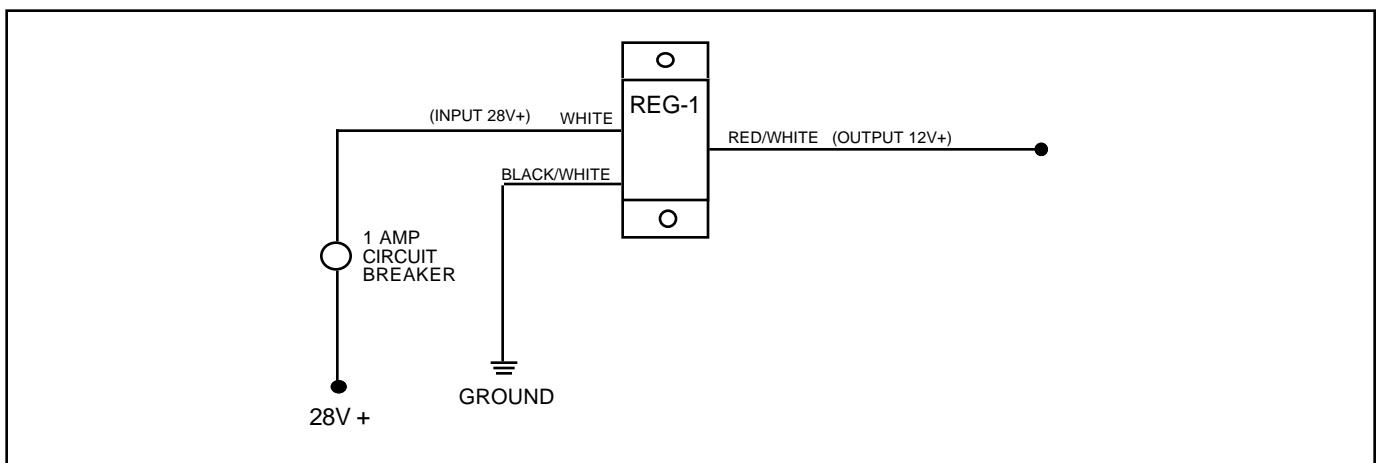
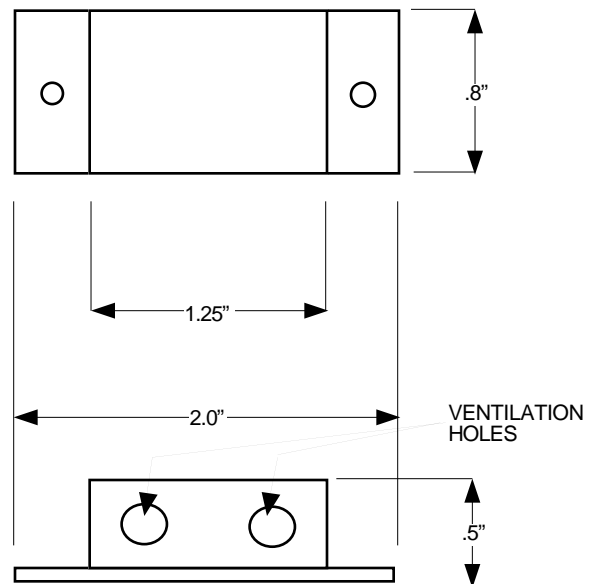

Warning: Installation and use of Ray Allen Company products is the responsibility of the aircraft designer and builder. Use of Ray Allen products in any application which will exceed their capability can cause failure leading to injury or death.